

GAS-CHAMP

9 PARTS LIST

9.1 MAIN UNITS

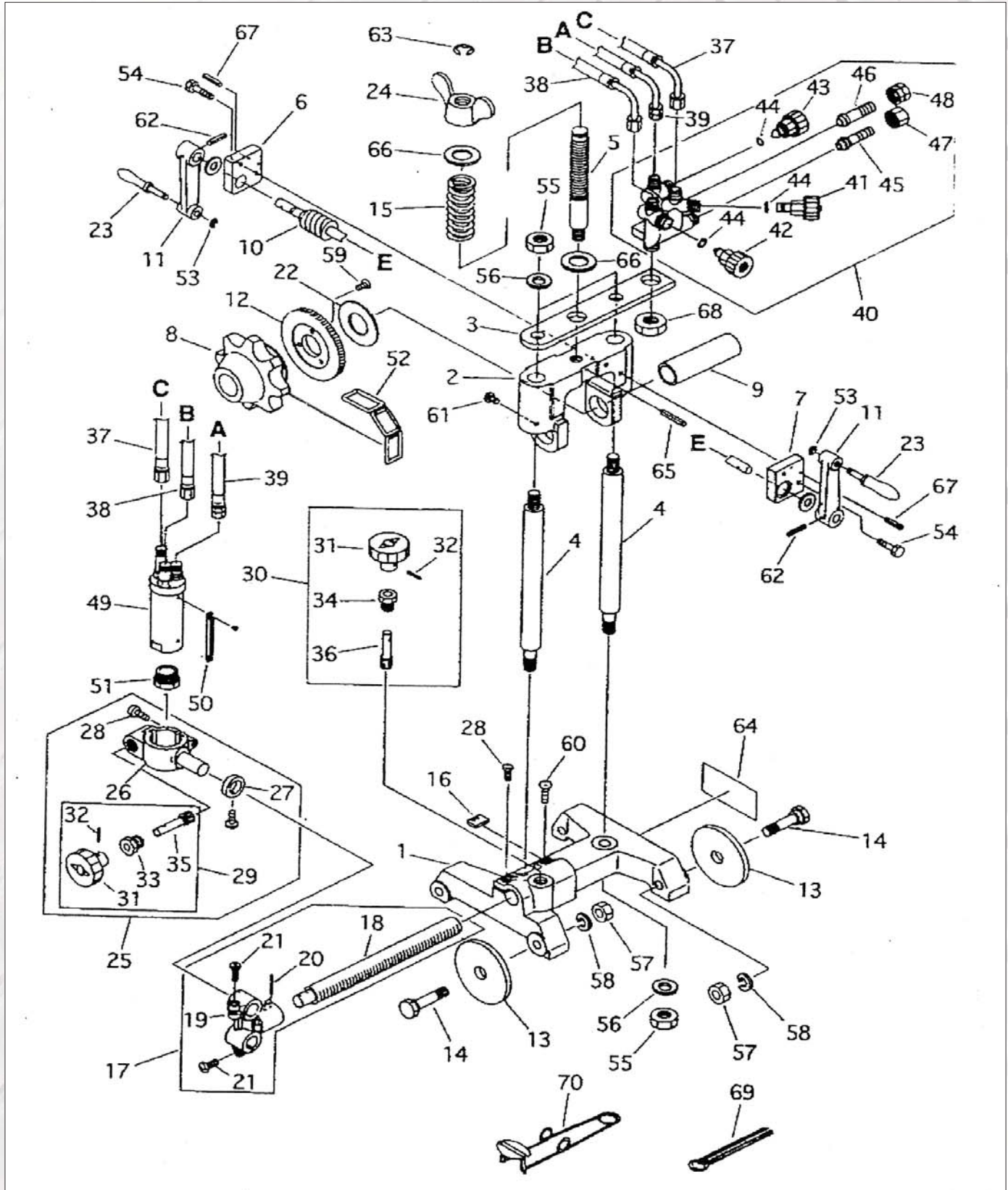

INDEPENDENT WHOLESALE WELDING SUPPLY

Ph: 02 8834 2400 Fax: 02 8834 2498 Email: iwws@iwws.net Website: www.iwws.net

GAS-CHAMP

MAIN AND DRIVING UNITS

ITEM NO	PART NAME	QTY	REMARKS
PC1	Body	1	
PC2	Slide bracket	1	
PC3	Upper plate	1	
PC4	Slide shaft	2	
PC5	Lift shaft	1	
PC6	Worm metal (right)	1	With brush
PC7	Worm metal (left)	1	With brush
PC8	Sprocket	1	
PC9	Sprocket shaft	1	
PC10	Worm shaft	1	With worm
PC11	Grip arm	2	
PC12W	Worm wheel	1	
PC13	Wheel	4	
PC14	Wheel shaft	4	
PC15	Spring	1	
PC16	Key	1	
PC17	Torch holder support assembly	1	
PC18	Bar	1	
PC19	Torch holder base	1	
PC20	Spring pin (PR-3x25)	2	Ø 3x25
PC21	Screw (SP-6x16)	2	M6x16
PC22	Collar (A)	1	
PC23	Grip	2	
PC24	Wing nut	1	
PC25	Torch holder assembly	1	
PC26	Torch holder	1	
PC27	Angle graduation ring	1	With screw
PC28	Screw (SP-6x16)	2	M6x16
PC29	Up/down handle assembly	1	
PC30	Cross feed handle assembly	1	
PC31	Handle (Ø 40)	2	Ø 2.5x16
PC32	Spring pin (PR-2.5x16)	2	Ø 2.5x16
PC33	Pinion metal	1	
PC34	Pinion metal	1	
PC35	Pinion	1	
PC36	Pinion	1	
OXY600	Hose for jet oxygen	1	M12 x 560 (Except USA , KE)
OXY600	Hose for preheat oxygen	1	M12 x 560 (Except USA)
ACET600	Hose for gas	1	M12 x 560 left (Except USA)
LPG600	Hose for gas	1	M12 x 560 left (Except USA)
PC40	Distributor	1	Except USA , KE
PC41	Valve for jet oxygen	1	Except KE
PC42	Valve for preheat oxygen	1	Except KE



INDEPENDENT WHOLESALE WELDING SUPPLY

Ph: 02 8834 2400 Fax: 02 8834 2498 Email: iwws@iwws.net Website: www.iwws.net

GAS-CHAMP

ITEM NO	PART NAME	QTY	REMARKS
PC43	Valve for gas	1	
PC44	O-ring	1	KS-5
PC45	Hose connector (Ox)	1	Except USA
PC46	Hose connector (Gas)	1	Except USA
PC47	Nut for oxygen	1	Except USA
PC48	Nut for gas	1	Except USA
PC49	Torch	1	Except USA, KE
PC50	Rack	1	With screw
PC51	Tip fixing nut	1	
PC52	Chain	1	2.4M
PC53	Stop ring	2	RS-5
PC54	Hexagon bolt (BH-6x25)	4	M6 x 25 with WS
PC55	Hexagon nut (NH-12)	4	M12
PC56	Washer (WF-12)	4	M12
PC57	Hexagon nut (NH-10)	4	M12
PC58	Washer (WS-10)	4	M10
PC59	Screw (SF-5x10)	3	M5 x 10
PC60	Screw (SP-3x15)	2	M3 x 15
PC61	Screw (SP-5x12)	1	M5 x 12
PC62	Spring Pin (PR-2.5x20)	2	2.5Ø x 20
PC63	Stop ring	1	RS-10
PC64	Name plate	1	
PC65	Spring pin (PR-3x32)	1	Ø3 x 32
PC66	Washer (WF-18)	2	M18
PC67	Spring pin (PR-2.5x20)	4	Ø2.5 x 20
PC68	Hexagon nut (NH-16)	1	M16
PC69	Tip cleaner	1	
PC70	Lighter	1	



INDEPENDENT WHOLESALE WELDING SUPPLY

Ph: 02 8834 2400 Fax: 02 8834 2498 Email: iwws@iwws.net Website: www.iwws.net

10 CUTTING DATA

Standard speed for acetylene
Metric System

PLATE THICKNESS (mm)	TIP SIZE	CUTTING SPEED (mm/min)	OXYGEN PRESSURE (kg/cm ²) / (Mpa)		FUEL GAS PRESSURE (kg/cm ²) / (Mpa)	KERF WIDTH (mm)
			CUTTING	PRE-HEAT		
3	00	680	1.5/0.15	1.5/0.15	0.2/0.02	1.0
6	0	610	2.0/0.2	2.0/0.2	0.2/0.02	1.3
10	0	560	2.0/0.2	2.0/0.2	0.2/0.02	1.5
12.5	1	530	2.5/0.25	2.5/0.25	0.2/0.02	1.8
19	2	460	3.0/0.3	3.0/0.3	0.25/0.025	2.0
25	2	430	3.0/0.3	3.0/0.3	0.25/0.025	2.0
38	3	355	3.0/0.3	3.0/0.3	0.25/0.025	2.3
50	4	320	3.0/0.3	3.0/0.3	0.25/0.025	2.8
60	5	280	4.0/0.4	4.0/0.4	0.3/0.03	3.0
75	5	250	4.0/0.4	4.0/0.4	0.3/0.03	3.0
100	6	200	4.0/0.4	4.0/0.4	0.3/0.03	3.6
125	6	180	4.0/0.4	4.0/0.4	0.4/0.04	3.6
150	7	150	4.5/0.45	4.5/0.45	0.4/0.04	4.1
200	7	130	4.5/0.45	4.5/0.45	0.4/0.04	4.3
250	8	80	4.5/0.45	4.5/0.45	0.4/0.04	5.6
300	8	50	4.5/0.45	4.5/0.45	0.4/0.04	6.6